

# OPERATION & INSTRUCTIONS FOR THE USE OF YOUR

Genesis  
Indoor Tanning Systems

Sundash  
Radius SR-48

*Notice: Any misuse, abuse, modifications, alteration, improper maintenance, improper installation, etc. of this product or its intended use will subject said party to direct responsibility and liabilities for any and all consequences resulting from such action. Furthermore, such actions will void all warranties and may relieve Sun Industries Inc. of any liabilities relating to said product.*

**Sun Industries, Inc.**  
P.O. Box 2026 Jonesboro, AR 72402  
**1-800-643-0086**

Part #007279

# SPECIFICATIONS

## SR-48

**DEPTH:** 50" Door Closed, 63" Door Open  
**WIDTH:** 39.5"  
**HEIGHT:** 85"  
**SHIPPING WEIGHT:** Approximately 1325 Lbs.  
**NO. OF LAMPS:** 48  
**ELECTRICAL:** 40 AMPS @ 240 VOLTS  
**CIRCUIT REQUIRED:** 120/208 VOLT, 1Ø 60 AMP  
120/240 VOLT, 1Ø 60 AMP

**DANGER - ULTRAVIOLET RADIATION. FOLLOW INSTRUCTIONS. AVOID OVEREXPOSURE. AS WITH NATURAL SUNLIGHT, OVEREXPOSURE CAN CAUSE EYE AND SKIN INJURY AND ALLERGIC REACTIONS. REPEATED EXPOSURE MAY CAUSE PREMATURE AGING OF THE SKIN AND SKIN CANCER. WEAR PROTECTIVE EYEWEAR; FAILURE TO MAY RESULT IN SEVERE BURNS OR LONG-TERM INJURY TO EYES.**

MEDICATIONS OR COSMETICS MAY INCREASE YOUR SENSITIVITY TO THE ULTRAVIOLET RADIATION. CONSULT PHYSICIAN BEFORE USING SUNLAMP IF YOU ARE USING MEDICATIONS OR HAVE A HISTORY OF SKIN PROBLEMS OR BELIEVE YOURSELF ESPECIALLY SENSITIVE TO SUNLIGHT. IF YOU DO NOT TAN IN THE SUN, YOU ARE UNLIKELY TO TAN FROM THE USE OF THIS PRODUCT.

THIS UNIT UTILIZES UVA LAMPS. REPLACE ONLY WITH GENESIS 200W SHRX FR 72-T12-SHRX-200W.

TO OBTAIN THE RECOMMENDED EXPOSURE POSITION OF A MINIMUM USE DISTANCE OF 6" (152.4 MM) MEASURED WITH A STANDARD RULER, STAND UPRIGHT ON DECAL IN FLOOR OF UNIT. THE USE OF ANY OTHER POSITION MAY RESULT IN OVEREXPOSURE.

RECOMMENDED EXPOSURE SCHEDULE					
SKIN TYPE	WEEK 1	WEEK 2	WEEK 3	WEEK 4	WEEKLY
	1 ST-3RD TREATMENTS	4TH-6TH TREATMENTS	7TH-10TH TREATMENTS	11TH-15TH TREATMENTS	SUBSEQUENT TREATMENTS
II - FAIR	2 MIN.	5 MIN.	8 MIN.	10 MIN.	12 MIN.
III - AVERAGE	2 MIN.	5 MIN.	8 MIN.	10 MIN.	12 MIN.
IV - BROWN	2 MIN.	7 MIN.	10 MIN.	12 MIN.	12 MIN.
V - DARK BROWN	2 MIN.	7 MIN.	10 MIN.	12 MIN.	12 MIN.

MAXIMUM EXPOSURE TIME IS 12 MINUTES.

TANNING CAN BEGIN ON A REGULAR BASIS. AN APPEARANCE OF TANNING NORMALLY APPEARS AFTER A FEW EXPOSURES AND MAXIMIZES AFTER FOUR (4) WEEKS OF EXPOSURE FOLLOWING THE RECOMMENDED SCHEDULE FOR YOUR SKIN TYPE.

USE PROTECTIVE EYEWEAR, SUPER SUNNIES, WHENEVER THE EQUIPMENT IS ENERGIZED. READ THE INSTRUCTION BOOKLET BEFORE USING THIS UNIT.

INSTRUCTIONS ACCOMPANYING THIS PRODUCT SHOULD ALWAYS BE FOLLOWED TO AVOID OR MINIMIZE POTENTIAL INJURY.

"THIS PRODUCT IS IN CONFORMITY WITH PERFORMANCE STANDARDS FOR SUNLAMP PRODUCTS UNDER CFR PART 1040."

# WARNINGS AND CAUTIONS

---

Certain drugs - particularly those that produce photosensitivity - may cause individuals under the influence of this type drug to experience adverse effects and those people should avoid exposure to UV sources of all kinds. Doctors will advise persons taking these drugs to possible adverse effects.

It is recommended that only one person at a time should use the tanning system while in use, and advises using protective eyewear while taking a tanning session. One pair of goggles is provided with each sunbed sold.

## WARNING

If you have been diagnosed by a physician as being allergic to the sun or are currently taking photosensitive medications, consult your physician before using the tanning unit.

Occasionally, persons using the tanning system will experience a slight reddening of the skin - usually in small patches - after the second or third session. This redness is often accompanied by an itching sensation. This may be nothing more than a heat "rash" caused by heat from the lamps within the system.

It should go away within approximately 24 hours and should not reappear. This rash can be lessened or prevented by applying moisturizer lotion to the affected area after the tanning session is completed.

## CAUTION

While there is no immediate clinical evidence regarding UVA exposure and its effects upon EXPECTANT MOTHERS, it is strongly advised that expectant mothers be discouraged from using the tanning unit.

## MANDATORY READING

Always read and follow all instructions for proper usage prior to using any tanning system.

### Remember:

1. Follow the exposure schedule in accordance with your skin type. Failure to do so may result in overexposure.
2. A tanning system is not a toy. You cannot vary the strength of the lamps in your unit.

Should you have any questions regarding the proper use of your tanning system, contact Sun Industries at:

**1-800-445-0624**

**8:00 a.m. to 5:00 p.m. (CST)**

Thank you for your cooperation.

# CARE AND CLEANING OF YOUR TANNING UNIT

After each session is completed, spray the acrylic surface with specially formulated UVT (ultra-violet transmitting) acrylic cleaner. Wipe the surface of the acrylic with a clean cloth.

The acrylic should never be wiped with a dry cloth because this will generate a slight static charge which will attract dust. A mild liquid detergent and water solution can be used temporarily in place of Acrylic Cleaner.

For maximum efficiency of your tanning unit, periodic cleaning of lamps, reflectors and the inside of the acrylics is required. Refer to relamping instructions for acrylic removal.

**CAUTION:** Do not use excessive amounts of water, any abrasive cleaners, or any spray cleaners that carry label warnings regarding reactions to contact with skin!

## DO NOT USE ALCOHOL OR AMMONIA

### Electrical Safety:

The tanning unit should be disconnected from the power supply before cleaning or disinfecting the inside of the acrylic. Avoid water or solution entering the lamp compartment.

# RELAMPING INSTRUCTIONS

1. Disconnect unit from power.
2. To remove acrylic from panel D (door panel), locate the six (6) 1/4 turn fasteners on the acrylic retainer strip on the left side of the panel. Using a flat head screwdriver, turn each fastener a 1/4 turn counter clockwise. You should hear a snap to release the strip. Repeat procedure on the remaining fasteners and remove the retainer strip.
3. Lift left edge of the acrylic approximately two (2) inches and slide acrylic to the left to remove.
4. Push lamp toward top of the unit to disengage lamp from stationary lampholder. Remove lamp. Repeat procedure for the remaining eleven (11) lamps in panel D.
5. Clean and replace acrylic sheet. To install acrylic sheet, slide the entire length of the right edge of the acrylic into the groove between the right rail and the acrylic retainer strip. Flush the acrylic with the groove in the left rail, and secure with the left acrylic retainer strip. To attach the acrylic retainer strip, align all six holes in the strip with the six holes in the left rail. Secure strip using a flathead screwdriver. Turn each fastener clockwise 1/4 turn. You should hear the fastener snap to secure the strip.
6. Proceed to panel C (next panel clockwise) and repeat procedures 2 through 5.
7. Upon completion of all panels, reconnect unit to power.

## CAUTION:

Replacement lamps must comply with CFR21 1040.20

- A. Replace only with "Genesis 200 SHRX FR72-T12 SHRX 200 W"
- B. When Ordering lamps, include model number and serial number.

# EXPOSURE TIME AND FREQUENCIES

Melanin - The brownish pigment produced by special cells in the base layer of your skin determines the individual's tan. As the skin is exposed to the ultraviolet light, the melanin is activated and combines with protein cells that rise to the skin's surface, thus producing a tan.

The amount of melanin in your body determines how quickly and dark you tan. The more melanin produced and exposure time an individual has, the faster and deeper the individual will tan.

## NOTE

THE TAN PRODUCED BY THE TANNING UNIT IS A DEEP, RICH "COSMETIC" TAN. HOWEVER, REGARDLESS OF HOW DARK AN INDIVIDUAL MAY TAN ON THIS SYSTEM, IT WILL NOT PROVIDE ADEQUATE PROTECTION AGAINST OVEREXPOSURE TO NATURAL SUNLIGHT OR UVB TANNING SYSTEMS.

**SKIN TYPE II** - This is the individual that usually burns easily and severely, tans minimally or lightly and peels.

**SKIN TYPE IV** - This individual burns minimally, tans easily and above average with each exposure.

**SKIN TYPE III** - Often referred to as "AVERAGE" complexion, burns moderately and tans about average.

**SKIN TYPE V** - This individual's system rarely burns, tans easily and substantially.

RECOMMENDED EXPOSURE SCHEDULE					
SKIN TYPE	WEEK 1	WEEK 2	WEEK 3	WEEK 4	WEEKLY
	1 ST-3RD	4TH-6TH	7TH-10TH	11TH-15TH	SUBSEQUENT
	TREATMENTS	TREATMENTS	TREATMENTS	TREATMENTS	TREATMENTS
II - FAIR	2 MIN.	5 MIN.	8 MIN.	10 MIN.	12 MIN.
III - AVERAGE	2 MIN.	5 MIN.	8 MIN.	10 MIN.	12 MIN.
IV - BROWN	2 MIN.	7 MIN.	10 MIN.	12 MIN.	12 MIN.
V - DARK BROWN	2 MIN.	7 MIN.	10 MIN.	12 MIN.	12 MIN.

**MAXIMUM EXPOSURE TIME IS 12 MINUTES.**

No two individual skin tones are the same. A tan to one person may be different to another and treatment length may vary.

### Note:

Adequate ventilation of the room or booth housing the tanning unit is required for proper and comfortable operation. Your tanning unit will perform best at the ambient temperature of 75° to 90° F.

It is recommended you do not use tanning

creams, oils or lotions intended for outdoor use. Equally important many facial make-ups have oil bases and should be removed prior to a session. It is recommended that, following a tanning session, a skin moisturizer be applied. This promotes a smoother, more even looking tan.

# ASSEMBLY INSTRUCTIONS

## Tanning Unit Assembly

### Step 1

Remove floor assembly from carton marked "Top"  
The floor of your tanning unit consists of - two (2) parts  
A- Base -lower floor  
B. Floor -upper floor

Illustration 1

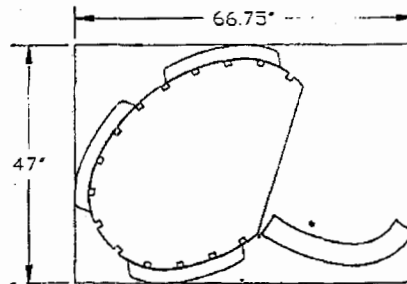

### Step 2

Position base in desired location. Align floor allowing a minimum of 63" from back of base to insure adequate distance to open door of unit properly. Also, allow a minimum of 18" around the parameter of the floor for ballast installation and access from the rear of the unit. (See **Illustration 1**)

NOTE: Check to insure all panel attachment latches are fully open. (See **Illustration 2**)

### Step 3

Remove panel B front box marked "PLB" and locate on base as shown in **Illustration 3**. Align slots in bottom plate of panel B with alignment pins in floor. Attach panel B to base with the two (2) attachment latches by placing the latch into slot in booth panel. Press downward on latch paddle, latch should snap into place securing panel B to base.

Illustration 2

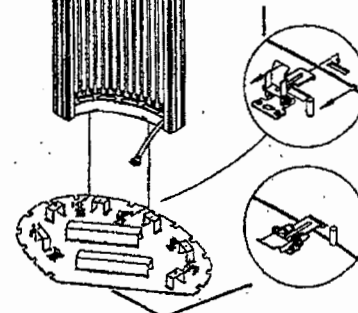

Illustration 3

### Step 4

Remove panel C from marked "PLC" and locate on base as shown in **Illustration 4**. Align slots in bottom plate of panel C with the alignment pins in floor. Align right side of panel C with left side of panel B, the side rails of both panels should nest together. Attach panel C to base with the two (2) attachment latches by placing the latch into slot in booth panel. Press downward on the latch paddle, latch should snap into place securing bottom of panel C to base. Attach panel C to panel B with the upper panel latch, located on the top of panel B by repeating the above latching procedure.

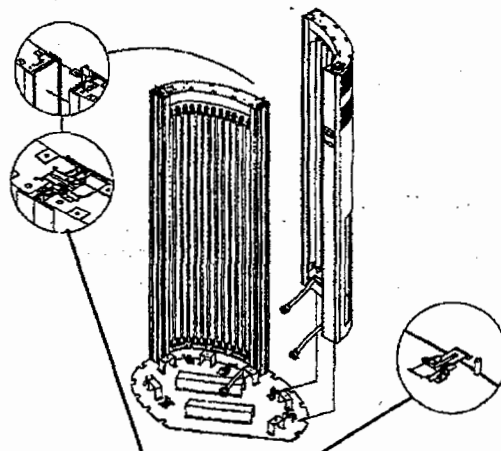

Illustration 4

---

## Step 5

Remove panel A from box marked "PLA" and locate on base as shown in **Illustration 5**. Align slots in bottom plate of panel A with the alignment pins in floor. Align left side of panel A with right side of panel B, the side rails of both panels should nest together. Attached panel A to base with the two (2) attachment latches by placing the latch into slot in booth panel. Press downward on latch paddle, latch should snap into place securing bottom of panel A to base. Attach panel A to panel B with the upper panel latch located on the top of panel B by repeating the above latching procedure.

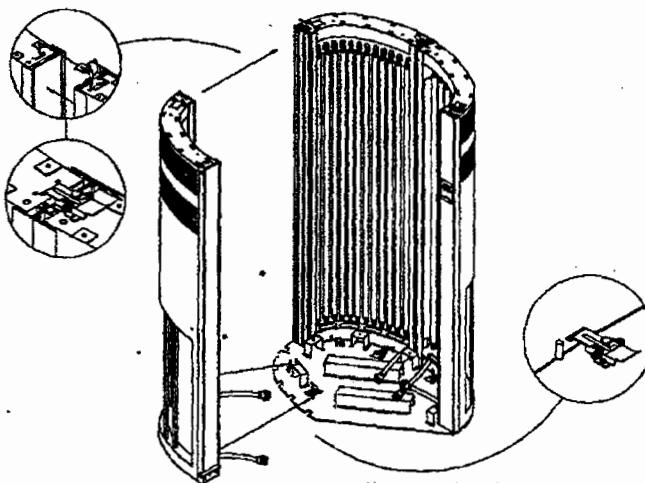

Illustration 5

## Step 6

Remove Panel D from box marked "PLD" and stand panel upright into position as shown in **Illustration 6**. Place plastic washer over both top and bottom hinge pins. Align hinge pins in door with hinges in Panel C, and allow hinge pins to drop into hinges. The door panel will re-hang on booth body.

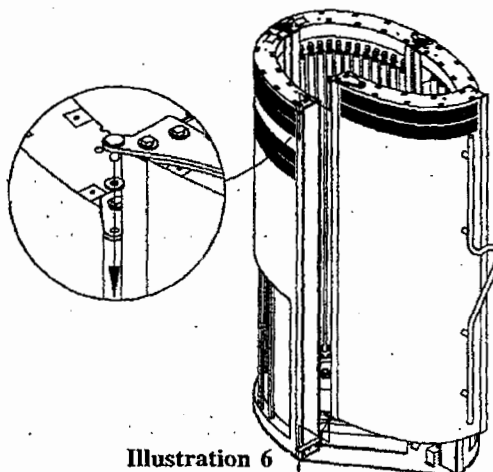

Illustration 6

## Step 7

Locate lamp harness and place on base as shown in **Illustration 7**. To connect lamp harness to panel A terminate harness to panel A cord 2 align plug and twist clock wise until locked. Repeat procedure for panel B cord 2, panel C cord 2 and door panel cord.

## Step 8

Locate panel A power cord 1 and connect with panel A cord 1. To terminate panel A cord 1 to power cord 1 align plug and twist clock wise until locked. Repeat procedure for panel B cord 1 and panel C cord 1. (see **Illustration 7**).

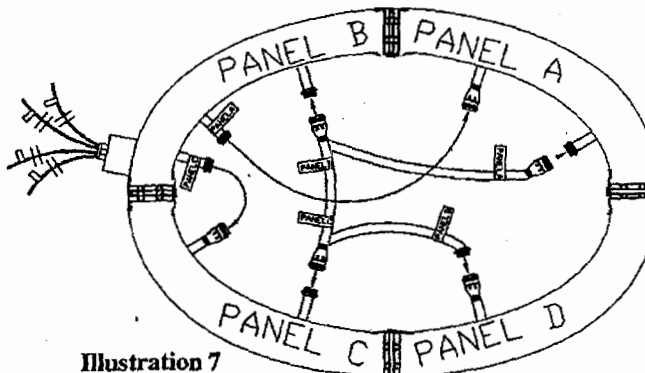

Illustration 7

## Step 9

Locate floor and place over base as shown in **Illustration 8**. Take note not to trap harness between base and floor. Attach floor to base with safety rails. By placing safety rail on threaded studs protruding thru floor. Tighten rails securely.

## Step 10

Remove top fan panel from box marked "Top". Place top fan panel on tanning unit as shown in **Illustration 9**. Attach top fan panel to tanning unit using the five (5) provided 5/16" - 18 x 1 bolts.

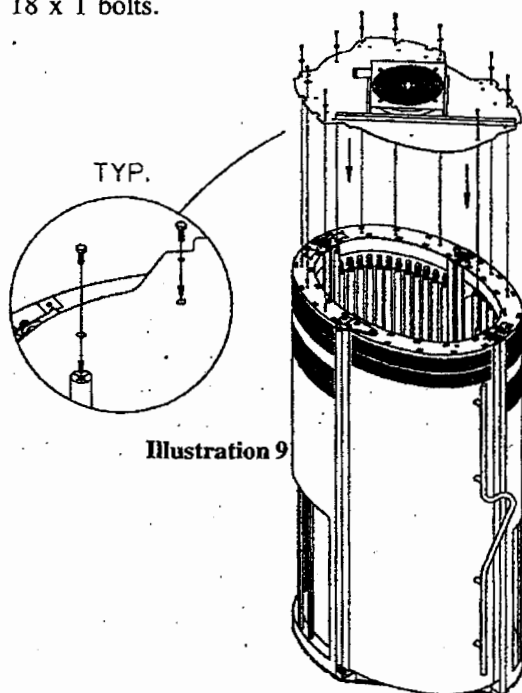
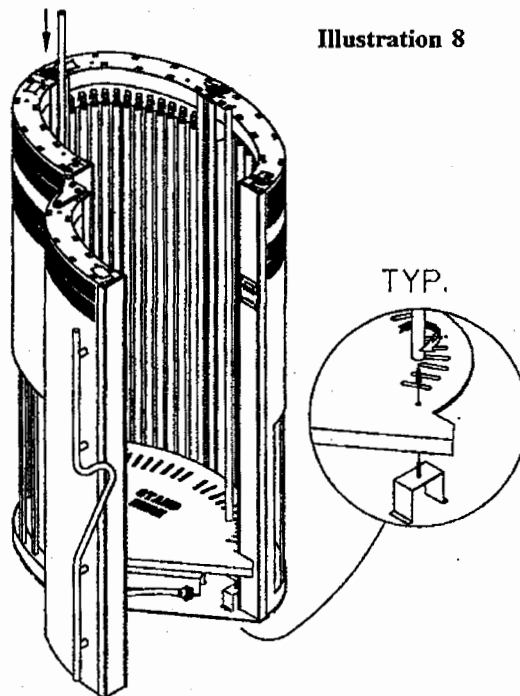

Illustration 8



## Step 11

Remove one (1) ballast panel from box marked "ballast". To install ballast panel slide tabs of ballast panel into slots at bottom of ballast access. To avoid later service problems please note that the interior harness is not

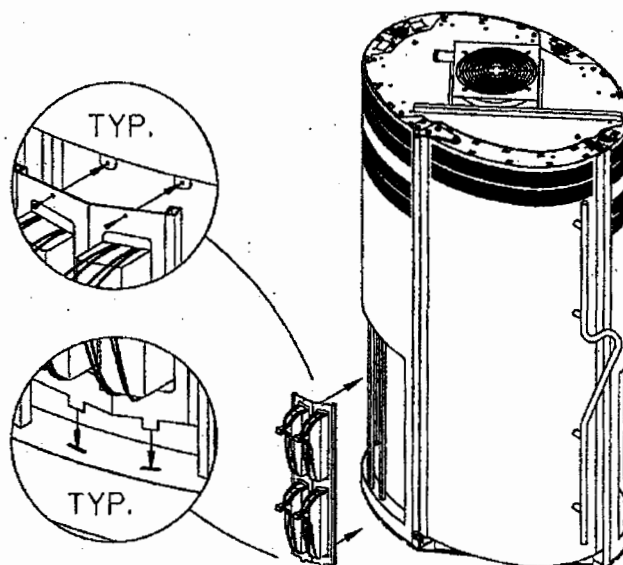
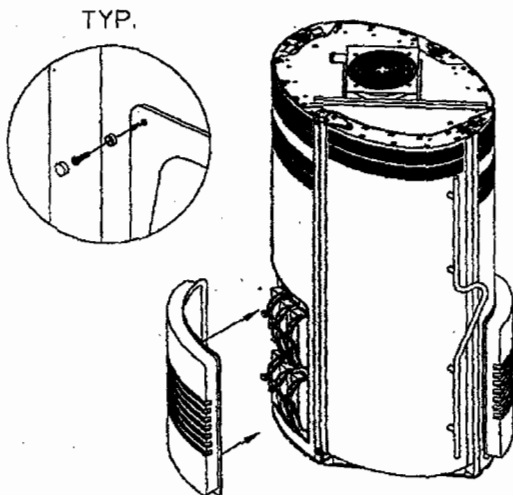

Illustration 10



trapped between ballast panel inner booth structure. Attach ballast panel to inner booth structure with two (2) of the provided # 6 x 3/8 philips screws tighten securely. See **Illustration 10**.

Connect ballast to power by terminating the nine conductor male harness plug with the female 9 pin ballast plug. See **Illustration 11**. Repeat procedure for remaining ballasts and ballast panels.



**Illustration 12**

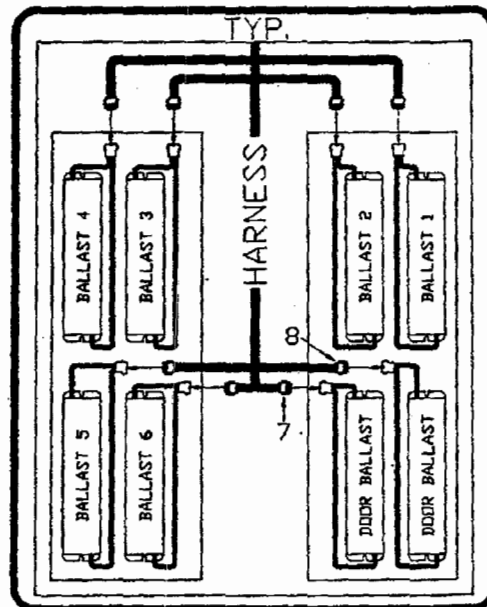

NOTE: #7 & #8 ARE FOR DOOR PANEL ONLY.

**Illustration 11**

## Step 12

Attach ballast access covers with #6 x 3/8 philips screws and snap caps. See **Illustration 12**.

## Step 13

Contact a local licensed electrician to connect electrical supply to unit. Your tanning booth requires a 120v/240v 1Ø 60 amp 4 wire service or a 120v/208v 1Ø 60 amp 4 wire service. See **Page 20** for detail.

# INTELLITAN PLUS

---

## BY SUN INDUSTRIES, INC. OPERATING INSTRUCTIONS

### To Set Time



STEP 1: Press  on the button labeled time to reach desired setting in minutes.

STEP 2: Press  to begin operation. The session is counted down in minutes and seconds.

NOTE: If a session delay is preprogrammed (P04), the display will begin to flash the session time. The display will *continue to flash the session time* for the duration of the session delay according to the programming or until the  button is pressed. If the

 button is pressed before the session delay expires, the display will stop flashing and the session time will begin to count down. At one (1) minute, before the start of the tanning session, an audible beep will sound (if programmed in P02). At thirty (30) seconds, before the start of the tanning session, another audible beep will sound. At ten (10) seconds the audible beep will sound and continue once each second until tanning unit lights. Once the tanning unit has started, the session delay will not repeat on subsequent restarts.

### To Stop Unit

STEP 1: Press  anytime during a session. This will stop the countdown and hold time. To restart the unit simply press .

### To Clear Time

STEP 1: Press  the timer clears to read 00:00



















NOTE: If the unit is counting down, the  button must be pressed before resetting.

---

## To Change Parameters

To enter the System's data bank, monitor operations and verify the vital functions concerning your unit, use the following step-by-step instructions. **Note:** Each timer manufactured after 1995 displays the current software version on power up. These instructions are for level 23 and above of the Intellitan Plus timer.

### Enter Password Clearance



1. Press (at the same time) then release  and  buttons; the display will change from 00:00 to 0000. If you cannot get the display to change to 0000, assure that you have disconnected the network cable(s) from the timer. If power to the tanning unit is not cycled on/off after disconnecting the network cable, you must wait for thirty seconds for the timer to award access to the above mentioned buttons.
2. Press the  button once so that 0000 begins to flash.
3. Use the  button to enter the appropriate password to perform the desired function. Password 0010 (ten) must be entered to view parameters, and 0102 (one hundred and two) to edit parameters. After entering the password press the  button. The display will stop flashing and 0001 (level one) or 0002 (level two) will appear in the display.
4. Press the  button to enter parameter mode, followed by  the button to reach the desired parameter. If you go past a parameter you may press the  to return to the desired parameter. Each time the  or  button is pressed the timer will display PXX (XX represents numbers) representing the parameter reached and the display will change showing the value of the parameter.
5. If you are using the second level password, press the  button to edit the parameter (once the  button is pressed the display will begin to flash). Use either the  or  button to set the appropriate value for the parameter, then press  to exit the parameter.
6. Press the appropriate  or  button to reach another parameter. You May press the  button to exit the edit parameter mode.

---

**P02** Parameter 2 is the chime mechanism that provides an audible "beep" sound when the keys are depressed and to indicate the various operations occurring. The audible beep can be turned on or turned off. The unit comes with the chime mechanism turned on to provide an audible beep.

When parameter 02 is shown, the display will read 0001. To maintain the chime mechanism, press the  now and go to P03. To silence it, do the following:

**To Change Parameter 2, Alarm On/Off**





Press  once then release it. The display will begin to flash. Press  and hold it down, scrolling down to 0000. Now  press once again. The chime is now deactivated. To reactivate the chime, change parameter 02 back to 0001 using the same instructions provided above.

Now press  to reach **Parameter 3 (P03), the Fan Delay or Post Session Cooling**

**P03** Parameter 3 is the fan delay. The fan delay maintains proper cooling of the tanning unit by continuing to provide power to the cooling fans for a programmable amount of time after the tanning session has completed. The unit comes with the fan delay preprogrammed at one (1) minute. Certain salon conditions may warrant a higher fan delay to maintain proper cooling. The fan delay cannot be turned off.

When parameter 03 is shown, the display will read 1.0 representing one minute. To change the fan delay, do the following:

**To Change Parameter 3, Fan Delay**

Press  once then release it, the display will begin to flash. Press either  or  to reach desired setting. Time is displayed from 1.0 to 5.0, with decimal representing tenths of a minute. For Example: 1.5 equals 1 minute, 30 seconds. After setting the fan delay press  once then release it. The fan delay is now set

---

**Important Note about the Fan Delay**

---

The duration of the fan delay is not displayed on the timer while the fan delay is counting down. Time is, however, displayed on the CCS-1 or other control device during the fan delay to indicate how long the fan delay has remaining. After a tanning session has expired, the colon ( \_\_ : \_\_ ) will flash and the numeric digits display will be blank (off). If the Clean Room feature is on then along with the flashing colon (:) dashes will appear in the display ( - - : - - ). When displayed on the CCS-1 or other control device the duration of the fan delay counts down in three second decrements.

When the Intellititan Plus timer is on a network no new time can be placed on the timer until after the fan delay has expired. The fan delay cannot be turned off.

---





Now press  to reach **Parameter 4 (P04), the Session Delay function.**

---

**P04** Parameter 4 is the session delay. The session delay allows a programmable amount of time at the beginning of a session to get ready for the tanning session. The tanning session time shown on the timer flashes during the session delay. The unit comes with no session delay preprogrammed.

**To Change Parameter 4, Session Delay**

When parameter 04 is shown, the display will read 0.0 for no session delay. To change the session delay, do the following:





Press  once then release it, the display will begin to flash. Now press  or  to reach the desired setting. Time is displayed from 0.0 to 10.0, with the decimal representing **tenths** of a minute. For Example: 2.5 equals 2 minutes, 30 seconds. After reaching the desired setting, press  once and release it. Session delay is now set.

Now press  to reach **Parameter 5 (P05)**, the **Station Address** function.

**P05** Parameter 5 is the station address. The station address allows the tanning unit to be identified for interface with the CCS series controllers, the Intellititan Single Station Console, or the Intellititan Protocol Interface (IPI) for your computer system. The unit comes with a station address of zero (0) preprogrammed, if you have multiple units each must be uniquely addressed.

**To Change Parameter 5, Station Address**

When parameter 05 is shown, the display will read 0000 for station address zero. To change the station address, do the following:



Press  once and release it, the display will begin to flash. Now press  or  to reach desired address setting. Once the desired setting is reached press  once and release it. The station address is now set.

Now press  to reach **Parameter 6 (P06)**, the **Lamp-Hour Accumulation on Current Lamp Bank** function.

**P06** Parameter 6 is the lamp hour accumulation counter. The lamp hour accumulation counter keeps track of the number of hours on the current lamp bank. This is a resettable parameter that should be reset to 0 when the lamps are changed. When current lamp hour accumulation reaches 0000, a beep will chime each time the unit is turned on, indicating that a lamp change is necessary. Chime will not sound if it has been turned off through parameter 2. Parameter 6 is only editable at password level 1.

When parameter 06 is shown, the display will read from 0000 to 9999. To clear the lamp hour accumulator, do the following:

**To Clear Parameter 6, Lamp Hour Accumulation**

Press  once and release, the display will begin to flash. Now press and hold  until 0000 is displayed.

---

When the display reads 0000 press  once and release. Lamp hour accumulation is now cleared.

Now press  once and release it to reach **Parameter 7 (P07)**, to measure **A/C Voltage Phase A**.

**P07** Parameter 7 is the measurement of the A/C voltage on phase A. The A/C voltage will be immediately displayed from 0000 to 0200 volts, with 0120 as the nominal reading.

Now press  once and release it to reach **Parameter 8 (P08)**, to measure **A/C Voltage Phase B**.

**P08** Parameter 8 is the measurement of the A/C voltage on phase B. The A/C voltage will be immediately displayed from 0000 to 0200 volts, with 0120 as the nominal reading.

Now press  and release it to reach **Parameter 9 (P09)**, to measure the **Average Voltage on Phase A**.

**P09** Parameter 9 is the measurement of average A/C voltage on Phase A for the previous session, or current session if unit is energized. The reading is immediately displayed.

Now press  and release it to reach **Parameter 10 (P10)** for measuring the average voltage on **Phase B**.

**P10** Parameter 10 is the measurement of average A/C voltage on Phase B for the previous session, or current session if the unit is energized. The reading is immediately displayed.

Now press  and release it to reach **Parameter 11 (P11)**, the measurement of the unit's **Operating Temperature**.

**P11** Parameter 11 is the measurement of the units internal operating temperature. The reading is immediately displayed. Measurement is in Fahrenheit.

Now press  and release it to reach **Parameter 12 (P12)**, the measurement of the unit's **Ambient Temperature**.

**P12** Parameter 12 is the measurement of the units ambient or room temperature. The reading is immediately displayed. Measurement is in Fahrenheit.

Now press  once and release it to reach **Parameter 13 (P13)**, the Measurement of the units **Average Operating Temperature**

**P13** Parameter 13 is the measurement of the units average operating temperature during the previous session or current session if the unit is energized. The reading is immediately displayed. Measurement is in Fahrenheit.



---

Now press  once and release it to reach **Parameter 14 (P14)**, the measurement of the **Average Ambient Temperature**.

**P14** Parameter 14 is the measurement of the average ambient or room temperature during a previous session or current session if the unit is energized. The reading is immediately displayed. Measurement is in Fahrenheit. Now press  once and release it to reach **Parameter 15 (P15)**, the **Clean Room Feature**.

**P15** Parameter 15 is the clean room feature. When on, the clean room feature will show all dashes (—) on the timer display at the end of each tanning session to show that the tanning unit needs to be cleaned. In network mode, no new time can be placed on the timer when the clean room indicator is displayed. To reset the clean room feature from the room, indicating that the room has been cleaned, press the  button twice in rapid succession. When the cleanroom feature is reset, the room timer will display 00:00. The unit comes with the clean room feature off.

**To Change Parameter 15, Clean Room Feature**

Press  once then release it, the display will begin to flash. Now press  once to display 0001, then press  once and release it. The Clean Room Feature is now enabled. To disable the Clean Room Feature simply change parameter 15 back to 00:00.

Now press  once and release it to reach **Parameter 16 (P16)**, **The Econometer**.



**P16** Parameter 16 is the Econometer. The Econometer measures the electrical cost to power unit for previous session or the current session if the tanning unit is active. The cost displayed is derived from the session cost per minute entered in P17. The reading is displayed immediately. Measurement is in cents and tenths of a cent. This function is read only and can not be changed.

For Example - A reading of 10.7 would equal 10.7 cents.

Now press  once and release it to reach **Parameter 17 (P17)**, **Cost Per Session**.

**P17** Parameter 17 is the session cost per minute. This figure is automatically entered into the tanning units data bank in accordance with the National Average of 7.5¢ per kilowatt hour. The formula used is Unit kWh Draw X National Average / 60 minutes = cost per minute. In the case of the R32B this is 3.1 x 7.5 / 60 = 0.388 rounded up to .4 cents per minute.

**To Change Parameter 17, Cost Per Minute**

Press  once then release it, the display will begin to flash. Now press  or  until the desired cost per minute is displayed. Measurement in cents and tenths of a cent. For Example: A reading of .4 would equal

---

four tenths of one cent. Once the desired reading is displayed press once and release it. The Cost Per Minute is now set.

Now press  once and release it to reach **Parameter 18 (P18), The Session Counter.**

**P18** Parameter 18 is the Session Counter. The session counter displays the total number of times a session has been started since first day of operation. The session counter counts from 0000 to 9999 then rolls over. The session counter cannot be adjusted or reset.

Now press  once and release it to reach **Parameter 19 (P19), Total Hour Accumulation.**



**P19** Parameter 19 is the total hour accumulator. This accumulator displays the total number hours on the unit since first day of operation. The accumulator counts from 0000 to 9999 then rolls over. The total hour accumulator cannot be adjusted or reset.

Now press  once and release it to reach **Parameter 24 (P24), Continuous Countdown Mode.**

**Note:** Parameters 20-23 are reserved for factory use.

**P24** Parameter 24 is the continuous countdown mode toggle. The default is 0 for disabled. The continuous countdown mode allows the salon owner to maintain a tighter schedule by disabling the pause function of the timer thus allowing the tanning time to continue to count down even if the lamps are turned off by pressing the start/stop key. This feature is only available with software level 16 or higher.

#### To Change Parameter 24, Continuous Countdown Mode

Press  once then release it, the display will begin to flash. Now press  until 0001 is displayed, press  once and release it. Next cycle the power to the timer and tanning unit off and back on. The Continuous Countdown Mode is now enabled. To disable this function change parameter 24 back to 0000.

Now press  once and release it to reach **Parameter 25 (P25), Keylock Configuration.**

**P25** Parameter 25 is the keylock configuration option. The default is 3 for 30 seconds. The keylock configuration option allows the salon owner to maintain a higher sense of security by locking out the front rail keys in several specified intervals while the timer is connected to a network. This feature is only available with software level 16 or higher. The keylock intervals are:



- 0 - Lock keys and release only when power cycled.
- 1 - Lock keys and release only when parameter is changed to an option other than 01.
- 2 - Lock keys and release only after the network cable has been removed for 2 minutes.
- 3 - Lock keys and release only after the network cable has been removed for 30 seconds.



---

**WARNING:** If you set parameter 25 to 01 (Lock until parameter changed) you will be unable to change this parameter or unlock the front rail keys without the use of a CCS-1 or other control device. The Intellitan Protocol Interface (IPI) does not edit this or any other parameter.



**To Change Parameter 25, Keylock Configuration**

Press  once then release it, the display will begin to flash. Now press  until the desired option 0,1,2,3 is displayed, press  once and release it. Next cycle the power to the timer and tanning unit off and back on. The Keylock Configuration is now saved.

Now press  once and release it to reach **Parameter 26 (P26), TPI Interface Enable.**

**P26** Parameter 26 is the Third Party Interface (TPI) Mode toggle. The default is 0 for disabled. The Intellitan Plus timer has a TPI jack built in to the timer itself. This jack replaces the need for a second or additional interface when using other timer systems. The TPI jack is located next to the two network jacks on the top of the tanning unit (under the hinge cover). It is the larger of the three jacks and comes with a unused modular plug in the jack. When using the Intellitan Plus timer in TPI mode the Intellitan Plus looks for control voltage (5-30v) on the outside two wires of the modular cable plugged into the TPI port. When this voltage is seen, the maximum tanning time is sent to the timer and the tanning unit is started. Any session delay should be programmed on the third party timer and the Intellitan session delay should be set to 0. The front rail keys are locked in TPI mode. This feature is only available with software level 16 or higher.

**To Change Parameter 26, TPI Mode**



Press  once then release it, the display will begin to flash. Now press  until 0001 is displayed, press  once and release it. Next cycle the power to the timer and tanning unit off and back on. The TPI Mode is now enabled. To disable this function change parameter 26 back to 0000.

Now press  once and release it to reach **Parameter 27 (P27), Timer Protocol Option.**

---

**P27** Parameter 27 is the Timer Protocol Option. The default is 0001 for Intellitan Protocol. The timer protocol option allows the salon owner to change timer network protocols from the Intellitan Network to the T-Max<sup>1</sup> protocol for use with the Applied Digital T-Max Manager. For additional information please consult the T-Max documentation. This feature is only available with software level 16 or higher.



**To Change Parameter 27, Timer Protocol Option**

Press  once then release it, the display will begin to flash. Now press  until 0001 is displayed, press  once and release it. Next cycle the power to the timer and tanning unit off and back on. The T-Max Protocol is now on. To turn off this function change parameter 27 back to 0000 using the parameter edit instructions in the T-Max documentation. You can not use a CCS-1 or IPI with a timer using T-Max Protocol.

Now press  once and release it to reach **Parameter 28 (P28), Total Operating Cost.**

**P28** Parameter 28 is the Total Operating Cost Accumulator. This parameter tracks total operating costs of the tanning unit based upon parameter 17, session cost per minute. This parameter is displayed in dollars and tenths and rolls over at \$999.9. The Total Operating Cost Accumulator can be reset to 0 at anytime in order to track or determine daily, weekly, monthly, quarterly, or annual operating costs.

**To Change Parameter 28, Total Operating Cost**

Press  once then release it, the display will begin to flash. Now press  until 0000 is displayed, press  once and release it. The Total Operating Cost is now reset to 0 and will begin accumulating at the next session.

# WIRING DIAGRAM

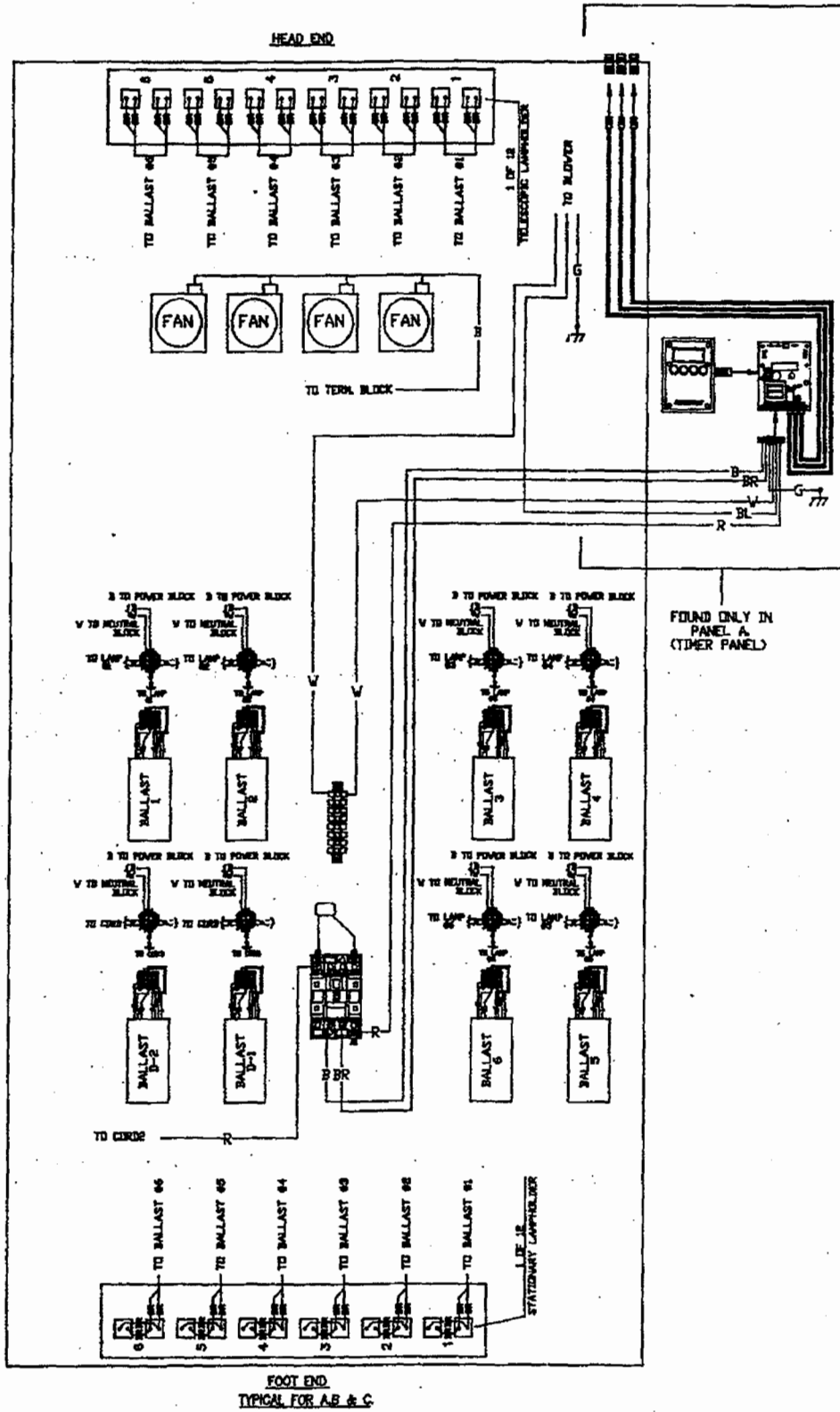

# RELAY WIRING DIAGRAM

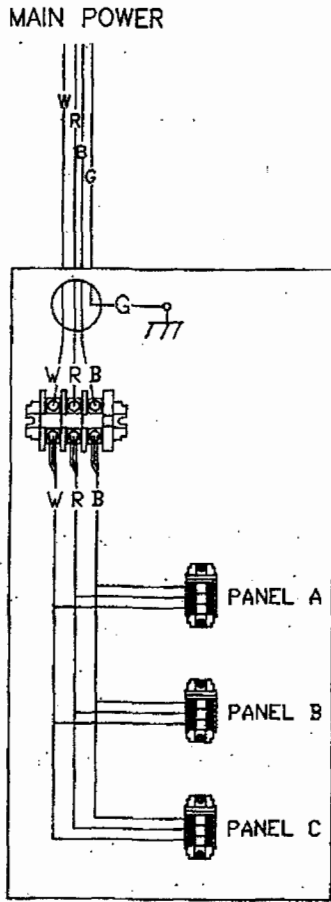

ELEC. JUNCTION BOX

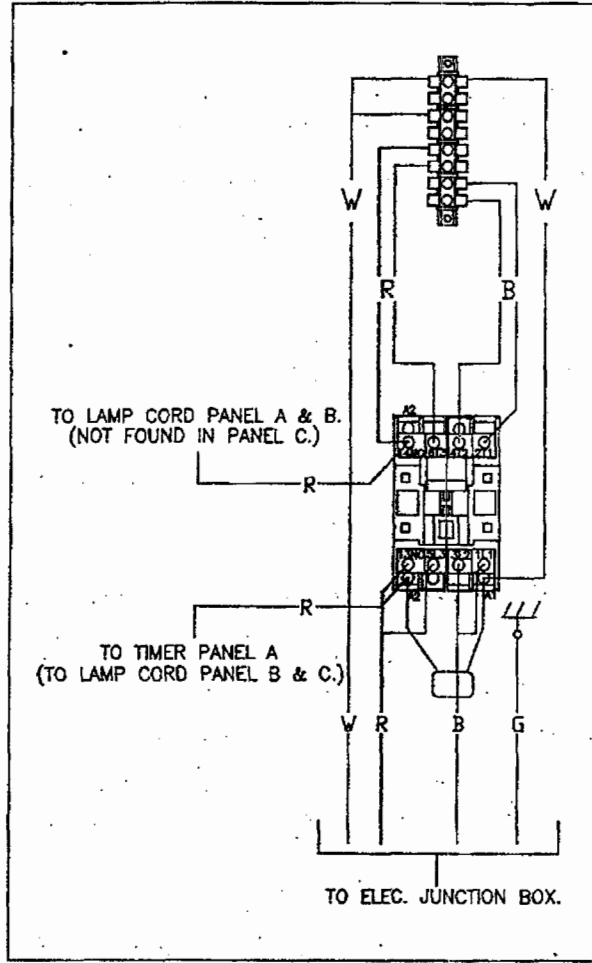

RELAY WIRING DIAGRAM  
TYPICAL FOR PANEL A, B & C.

# SUPPLY WIRING DIAGRAM

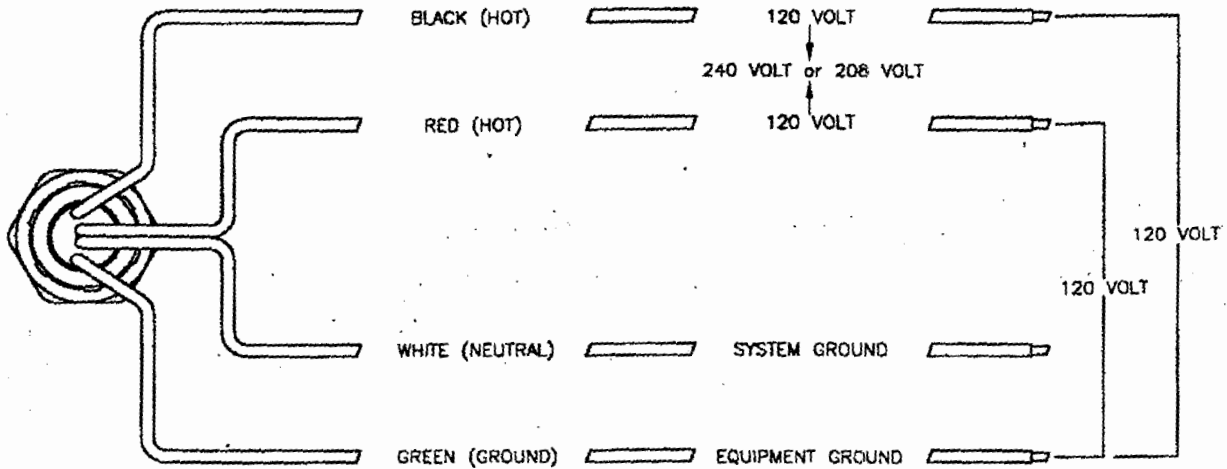

## CIRCUIT REQUIRED

120/208 VOLT, 1Ø 60 AMP

120/240 VOLT, 1Ø 60 AMP

3/4" FLEXIBLE CONDUIT CONNECTION

ALL FOUR (4) POWER WIRES

6 GA. OR LARGER

# **GENERAL TROUBLESHOOTING GUIDE**

---

The following troubleshooting information is divided into two sections. Section A contains items in which the owner may check without the aid of a service person. Section B contains items which must be performed by **QUALIFIED SERVICE PERSONNEL ONLY**. If you have any questions other than the ones listed in your troubleshooting guide, contact your dealer or distributor.

**(NOTE: All tanning units are not the same, therefore some of the causes may not apply to your unit.)**

## **General Troubleshooting (Section A)**

1 Tanning unit does not operate.

### **CAUSE**

1. No power to unit.
2. Timer is not activated.

### **SOLUTION**

1. Check circuit breaker servicing bed.
2. Press up button, then start button.

**NOTE: If there is power to the unit but the display on the timer is not lighting, you may need to replace the timer board. Contact Sun Industries or your local representative for information.**

2. Lamps won't light or lamps flicker.

### **CAUSE**

1. Lamp not seated properly in lamp holder.
2. Faulty lamp.

### **SOLUTION**

1. Remove lamp, inspect contacts on lamp, and reinstall lamp securely into lamp holder.
2. Replace lamp. (Refer to Instruction Manual for correct lamp).

## General Troubleshooting (Section B)

---

All services in the following section are to be completed by a Qualified Service Technician. This section is to aid in isolating and correcting any problems which may occur and is not intended for use by the owner. Refer to the assembly instructions included with each unit for reference in disassembling and wiring the tanning unit. Disconnect all power to the unit before servicing. Use only factory authorized service personnel.

1. Tanning unit does not operate.

### CAUSE

1. Incorrect connection of incoming power.
2. Faulty timer.
3. Faulty relay in bed.

### SOLUTION

1. Check electrical connections on wiring diagram and correct as necessary.
2. Replace
3. Replace
4. Check wiring circuit against appropriate wiring diagram and correct as required.

2. Lamps won't light.

### CAUSE

1. Poor wiring crimp at lamp holder.
2. Faulty or damaged lamp holder.
3. Incoming power to unit incorrect.
4. Faulty ballast.
5. Loose power wire to ballast.

### SOLUTION

1. Check for loose wire and repair.
2. Replace.
3. Check incoming voltage and correct to requirements.
4. Locate and replace.
5. locate loose wire and repair.

# IMPORTANT NOTE

## PREVENTIVE MAINTENANCE SCHEDULE

Your Genesis Tanning System consists of many movable parts that may require periodic adjustments and/or replacement.

It is imperative that you, the owner and/or operator, check all components for any signs of wear which may occur through normal use.

The frequency of your preventive maintenance schedules should be determined according to equipment usage. The minimum of a monthly inspection of all components is a good guideline, however, actual frequency and thoroughness of inspections is your responsibility.

Should you require any assistance or need additional information, please call our Service Department at 1-800-445-0624, Monday through Friday 8:00 a.m. -5:00 p.m. CST

## REPAIRS-SERVICE-REPLACEMENT PARTS AND LAMPS-EYE PROTECTION

If you are in need of any of the above mentioned products or services, you should contact the dealer/distributor through whom you purchased your unit. In the event that you are unable to do so, please call our Service Department for assistance at: 1-800-445-0624.

**NOTE:** All repairs and replacement components including, but not limited to, protective eyewear, lamps, timers, acrylic and reflectors must be in compliance with CFR 21 1040.20.

## ACCESSORY ITEMS

Contact our Merchandising Department to order all your tanning supplies including lotions, moisturizer, accelerators, shower gels, acrylic cleaner and a complete selection of both home and commercial tanning accessories. Call 1-800-235-8555.

# SUN INDUSTRIES, INC.

---

## LIMITED WARRANTY

Sun Industries, Inc. warrants its products to be free from defects in materials and workmanship under intended normal use as described in the unit's Operation and Instruction Manual, for a period of one (1) year from date of sale.

This Limited Warranty applies only to the original purchaser of the equipment through Sun Industries, Inc. or its authorized dealer or distributor, and is not transferable.

Sun Industries, Inc.'s obligations under this warranty are limited to repair or replacement of any defective part without charge for that part to the original purchaser, with the following exceptions:

- A. Fluorescent lamps are warranted against defects for a period of thirty (30) days from date of sale.
- B. Only parts obtained through Sun Industries, its authorized dealers or distributors may be used. Transportation costs for parts shipped to the consumer and the return of defective parts to Sun Industries are not included.
- C. Labor will be furnished without charge for ninety (90) days from date of purchase only. All labor and related charges must be authorized by Sun Industries prior to start of repairs, and must coincide with Sun Industries, Inc.'s established rates and time allotment policy.
- D. Acrylic: Refer to Manufacturer's Acrylic Warranty Policy.

It is imperative that the original customer completes and returns the enclosed warranty card within 10 days after purchase to insure valid registration and coverage for potential claims.

If the warranty card is not registered, proof of purchase from Sun Industries, Inc. or its authorized dealer or distributor will be required prior to any consideration on warranty claims. This could result in service delays.

This warranty is extended to the individual or legal entity, whose name appears on the warranty registration card filed with Sun Industries, Inc., or whose name appears on the original sale document and may not be transferred to any other individual or legal entity.

This warranty does not apply to any failure of the product, or any parts of the product due to alterations, modifications, misuse, abuse, accident, improper maintenance, improper installation, acts of God or if the serial number on the product has been removed, altered or defaced. Adequate packaging must be used for returned goods to prevent freight damage.

**THERE ARE NO WARRANTIES WHICH EXTEND BEYOND THE DESCRIPTION ON THE FACE HEREOF. THERE IS NO EXPRESS OR IMPLIED WARRANTY OF FITNESS OR MERCHANTABILITY.**

**THE REMEDIES PROVIDED IN THIS LIMITED WARRANTY ARE THE EXCLUSIVE REMEDIES PROVIDED TO THE PURCHASER BY SUN INDUSTRIES, INC. AND ARE PROVIDED IN SUBSTITUTION OF ALL OTHER REMEDIES - CONSEQUENTIAL AND INCIDENTAL DAMAGES ARE EXCLUDED.**

No person, firm or corporation is authorized to obligate Sun Industries, Inc. for any liability in connection with the sale or use of these goods.



# **LIMITED ACRYLIC WARRANTY**

---

Sun Industries, Inc. warrants its acrylic sheets to be free from defects in material and workmanship, under intended normal use, for a period of one (1) year from date of sale of the tanning bed. Due to the tanning lotions, cosmetics, disinfectant and improper cleaners used on tanning surfaces that cannot be controlled by Sun Industries, Inc., after the first thirty (30) days of warranty period. Acrylic will be subject to a prorated cost to the consumer on breakage.

Sun Industries, Inc.'s obligations do not include transportation charges on replacement acrylic.

Sun Industries, Inc. assumes no liability for the cost of removing defective sheets or installing replacement sheets, nor for damage to persons or property.

To make a claim, contact an authorized dealer or distributor of Sun Industries, Inc. or Sun Industries, Inc. Service Department with the model number, the serial number, and the date of purchase of the bed in which the acrylic will be used.

**THERE ARE NO WARRANTIES WHICH EXTEND BEYOND THE DESCRIPTION ON THE FACE HEREOF. THERE IS NO EXPRESS OR IMPLIED WARRANTY OF FITNESS OR MERCHANTABILITY.**

**THE REMEDIES PROVIDED IN THIS LIMITED WARRANTY ARE THE EXCLUSIVE REMEDIES PROVIDED TO THE PURCHASER BY SUN INDUSTRIES, INC. AND ARE PROVIDED IN SUBSTITUTION OF ALL OTHER REMEDIES - CONSEQUENTIAL AND INCIDENTAL DAMAGES ARE EXCLUDED.**

**Sun Industries, Inc.**  
P.O. Box 2026  
Jonesboro, Arkansas 72402  
1-800-445-0624  
870-935-1130 (in Arkansas)

# **WARRANTY CLAIMS POLICY & PROCEDURES**

---

## **1. When to file a Warranty Claim:**

In the event that your tanning system is not functioning properly under intended normal use as described in the unit's Operation and Instruction Manual, you may then have established cause to file a Warranty Claim.

**NOTE:** Both the tanning system and legal registered owner must meet the criteria established under Sun Industries, Inc.'s Limited Warranty as described in this manual before any Warranty Claim will be considered.

## **2. Where to call to place a Warranty Claim:**

Sun Industries, Inc. is supported nationwide by an extensive dealer/distributor network through whom the majority of our units are sold. These dealers/distributors are required by contract to stock sufficient parts to meet the various warranty and nonwarranty needs of their customers.

Therefore, in order for you to properly file a Warranty Claim, you must locate the name and phone number of the dealer/distributor through whom you purchased your unit. Normally this information can be easily located either on your paid invoice or other proof of purchase documentation that you received when taking delivery of the unit.

Next, notify the dealer/distributor of the serial number, model number and date unit was purchased. This will initiate the Warranty Claim process.

Upon determination of the problem, your dealer/distributor can then supply you with the part(s) and proper instructions to return your unit to working order.

Each dealer/distributor has their own internal procedure for handling Warranty Claims and credits.

**NOTE:** Sun Industries, Inc., the manufacturer, does not involve itself in the direct handling of a Warranty Claim except where mitigating circumstances apply and where required by law.

# **PARTSWARRANTY CLAIM/CREDIT REVIEW**

---

1. Customer calls Sun Industries, Inc. and notifies the Service Department of problem.
2. Sun Industries, Inc.'s Service Department determines course of action.
3. Sun Industries, Inc. ships part and R.A.I. to customer freight collect and bills customer on net 30 basis for part only.
4. Customer, within 15 days of receiving new part, returns defective part to Sun Industries, Inc. along with R.A.I.
5. Upon receipt of defective part and R.A.I., Sun Industries, Inc. issues customer a credit invoice which offsets original bill. Customer's account is returned to zero balance concerning this claim.

**NOTE:** If part returned to Sun Industries, Inc. proves to be operational and not defective, or if product code numbers on part do not correspond with individual unit date on file with Sun Industries, Inc., then a 30% restocking fee will be charged in addition to the retail purchase price of part.

Acknowledgement of the Agreement is not required for acceptance of the foregoing stipulations.

## **LABOR WARRANTY CLAIM/CREDIT PROCEDURES**

Sun Industries, Inc. furnishes labor without charge for a period of 90 days from date of purchase. All labor and related charges must be authorized by Sun Industries, Inc. prior to start or repairs, and must coincide with Sun Industries, Inc.'s established rates and time allotment policy.

Please contact our Service Department for authorization and billing procedures.

